

Safety signals

Important information concerning safety is distinguished in this manual by the following notations.



The Safety alert symbol means:

Caution! Your safety is involved.

WARNING!

Failure to follow warning instructions could result in **severe or fatal injury** to anyone working with, inspecting or using the steering damper, or to bystanders.

CAUTION!

Caution indicates that special precautions must be taken to avoid damage to the steering damper.

NOTE!

This indicates information that is of importance with regard to procedures.

Kit contents

Before installing the steering damper, please check the contents of the kit, listed on the front page of this instruction. If anything is missing, contact your Öhlins dealer.

Öhlins Racing AB can not be held responsible for any damage whatsoever to shock absorber or vehicle, or injury to persons, if the instructions for fitting and maintenance are not followed exactly. Similarly, the warranty will become null and void if the instructions are not adhered to.

NOTE!

During storage and transportation, especially at high ambient temperature, the oil and grease used for assembling may run out inside the packing and damage the expanded polystyrene packing material. This is not unusual and is in no way detrimental to the steering damper.

Öhlins products are subject to continual improvement and development. Consequently, although these instructions include the most up-to-date information available at the time of printing, there may be minor differences between your steering damper and this manual. Please consult your Öhlins dealer if you have any questions with regard to the contents of the manual.

Mounting Instructions

1

Put the motorcycle on a stand and make sure it's steadily fixed so it will not fall over.

WARNING!

1. It's advisable to have an Öhlins dealer or other qualified person to fit your steering damper.

2. Instructions in the vehicle service manual are to be followed when changing the steering damper.

6

Adjust the brackets so the length of the stroke of the steering damper is equal when turning left and right.

NOTE!

Make sure that there are no problems for clearance when turning the steering to the left and right end positions and that the damper not is used as a stopper.

2

Mount the bracket parts 02267-05 and -06 on the left side of the frame. Use bolts 01046-01

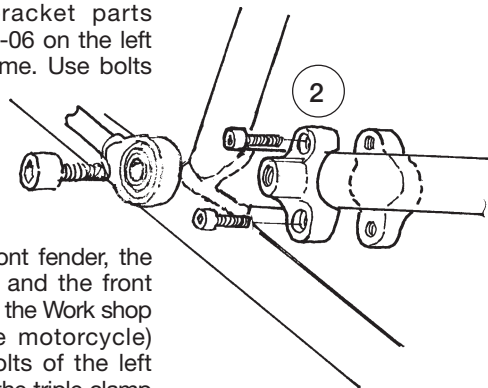

3

Remove the front fender, the brake calipers and the front wheel. (Refer to the Work shop manual of the motorcycle) Loosen the bolts of the left handlebar and the triple clamp bolts for the left fork leg. Lower the front fork leg and fit the clamp according to the drawing.

4

Refit the fork leg and the handlebar and tighten the bolts. Put the front wheel, the brake calipers and the front fender back on the motorcycle. Tighten the clamp by the M6x25 bolt.

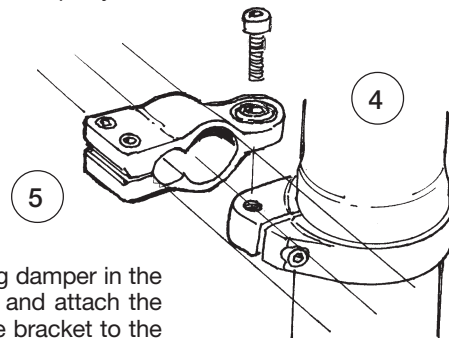

5

Fit the steering damper in the bracket assembly and attach the end eye of the bracket to the clamp with the spacer between the bracket and the clamp. Use the bolt M8x25 provided.

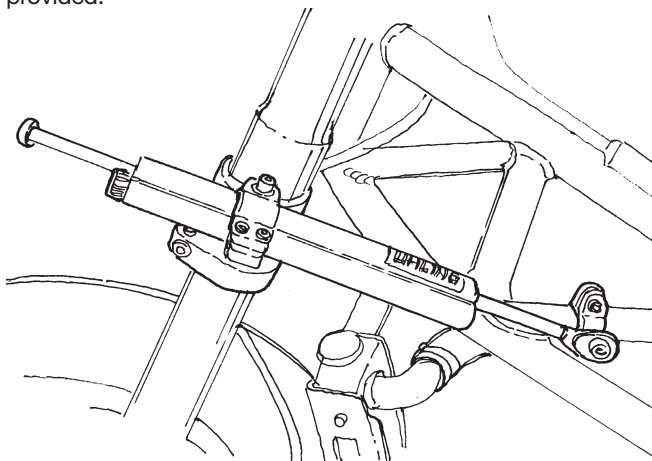

Before you start

WARNING!

1. Installing a steering damper, that is not approved by the vehicle manufacturer, may affect the stability of your vehicle. Öhlins Racing AB cannot be held responsible for any personal injury or damage whatsoever that may occur after fitting the steering damper. Contact an Öhlins dealer or other qualified person for advice.

2. Please study and make certain that you fully understand all the mounting instructions and the owner's manuals before handling this steering damper kit. If you have any questions regarding proper installation procedures, contact an Öhlins dealer or other qualified person.

3. The vehicle service manual must be referred to when installing the Öhlins steering damper.

© Öhlins Racing AB.
All rights reserved.

Any reprinting or unauthorized use without the written permission of Öhlins Racing AB is prohibited.
Printed in Sweden.