

Before installing this product, check the contents of the kit. If anything is missing, please contact your nearest Öhlins dealer.

**Kit Contents**

	Part No.	Pcs.
Steering damper	SD 021	1
Öhlins sticker	00192-01	2
Öhlins Owner's manual	07261-01	1

Please note that during storage and transportation, especially at high ambient temperature, some of the oil and grease used for assembling may leak and stain the packaging. This is in no way detrimental to the product, wipe off the excessive oil/grease with a cloth.

**⚠ Warning!**

Before installing this product, read the Öhlins Owner's Manual. The shock absorber is an important part of your vehicle and may affect the stability.

👁 Öhlins products are subject to continuous improvement and development, therefore, although these instructions include the most up-to-date information available at the time of printing, minor updates may occur. To find the latest information contact your Öhlins distributor. Please consult your Öhlins dealer if you have any questions regarding the contents in this document.

© Öhlins Racing AB. All rights reserved. Any reprinting or unauthorized use without the written permission of Öhlins Racing AB is prohibited.

Öhlins Racing AB  
Box 722  
S-194 27 Upplands Väsby, Sweden  
Phone +46 8 590 025 00  
fax +46 8 590 025 80

Part no. SD 021\_2  
Issued 2009-03-25

## Steering Damper for Kawasaki ZX6R/ ZX10R **SD 021**

### Mounting Instructions



**⚠ Warning!**

*It is advisable to have an Öhlins dealer install the steering damper.*

*When installing, consult your Vehicle Service Manual.*

**1**

Remove the original steering damper.

**2**

Install the SD 021 Steering Damper in the same way as the original unit. Use original attachment parts.

**3**

Set the damper to the recommended set-up in this folder.

**👉 Caution!**

*Make sure that all screws are tightened to the correct torque and that nothing fouls or restricts movement of the steering damper.*

**⚠ Warning!**

*Before riding, always make sure that the basic settings made by Öhlins are according to recommended Set-up Data. Read about adjustments and setting up in the Öhlins Owner's Manual before you make any adjustments. Contact an Öhlins dealer if you have any questions about setting up the steering damper.*

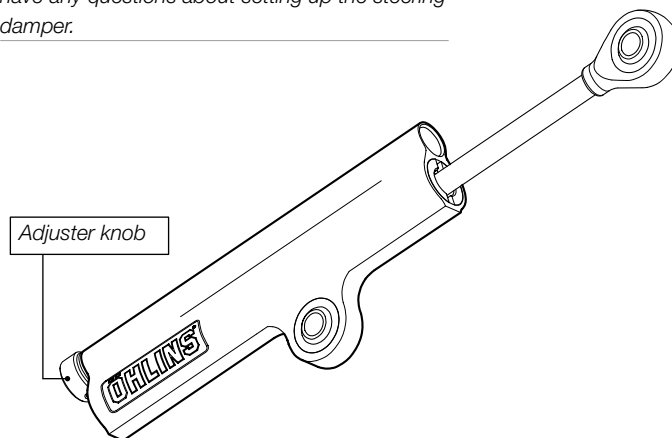

## Set-up Data

Recommended set-up

10 clicks