

**👁 Note!**

Please note that there can be small differences between your product and the images in these instructions.

**👁 Note!**

Please note that during storage and transport, especially at high ambient temperature, some of the oil and grease used for assembly may leak and stain the packaging. This will not cause damage to the product, wipe off the excessive oil or grease with a cloth.

**Kit Contents**

Description	Part No	Pcs
Shock absorber	KT 302	1
Spacer	01218-67	4
Seal	00534-01	4
Sticker Öhlins wh/tr	01185-01	2
Sticker Öhlins bl/tr	01185-04	2
Sticker Memo notes	01180-01	1
Owner's Manual	07242-05	1

**👁 Note!**

Before you install this product, check the kit contents. If anything is missing, please contact an Öhlins dealer.

**⚠ Warning!**

Before you install this product, read the Öhlins Owner's manual. This product is an important part of the vehicle and the vehicle stability.

## Shock absorber for KTM 1290 Super Duke R

# **KT 302**

## Mounting Instructions

# MOUNTING INSTRUCTIONS

## **⚠ Warning!**

*We strongly recommend to let an Öhlins dealer install this product.*

## **⚠ Warning!**

*If you work with a lifted vehicle, make sure that it is safely supported to prevent it from tipping over.*

## **👁 Note!**

*When you work with this product, see the vehicle service manual for vehicle specific procedures and important data.*

## **👁 Note!**

*Before you install this product clean the vehicle.*

**1**

Put the motorcycle on a work stand so that the rear wheel barely touches the ground.

**2**

Remove the seat.

**3**

Remove the silencer and catalytic converter so that you can lower the rear wheel later in the installation procedure.

**4**

Loosen the ECU with rubber mounting from its brackets.

**5**

Remove the plastic cover below the ECU.

**6**

Loosen the rear sub frame completely and lift/tilt it upwards, you may need to cut some tie-raps holding the wire harness and also loosen the tank to get the rear sub frame high enough.

**7**

Remove the installed shock absorber.

**8**

Use the seals (B) and the spacers (A) provided in the kit for the upper and lower mounting points and install the Öhlins shock absorber with the reservoir pointing to the right side of the vehicle.

**9**

Assemble the motorcycle in reverse order.

## **👁 Note!**

*Lower the vehicle so that the suspension is slightly compressed before you tighten the screws.*

## **👋 Caution!**

*Make sure that you tighten all screws to the correct torque and that nothing fouls or restricts movement of the shock absorber/front fork/steering damper when the suspension is fully compressed or extended.*

# MOUNTING INSTRUCTIONS

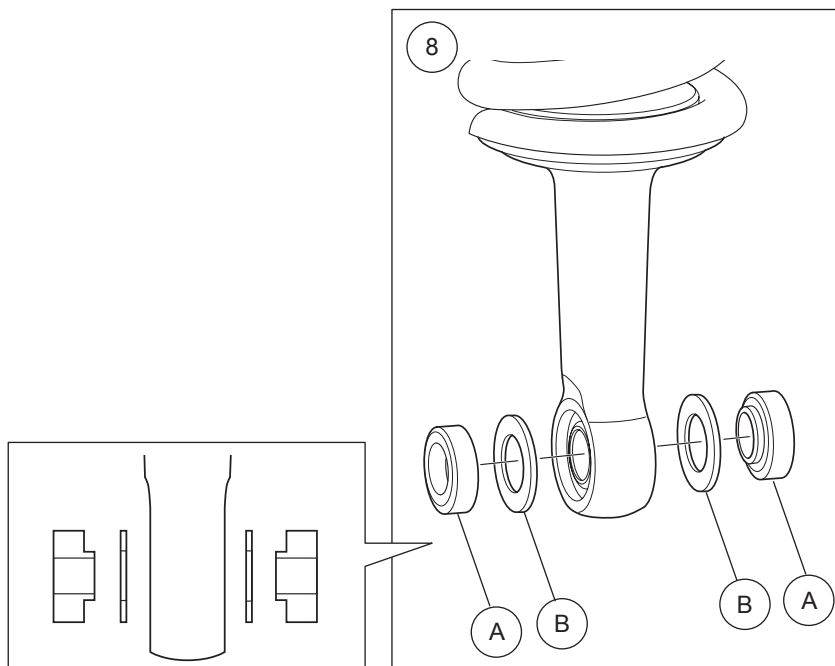
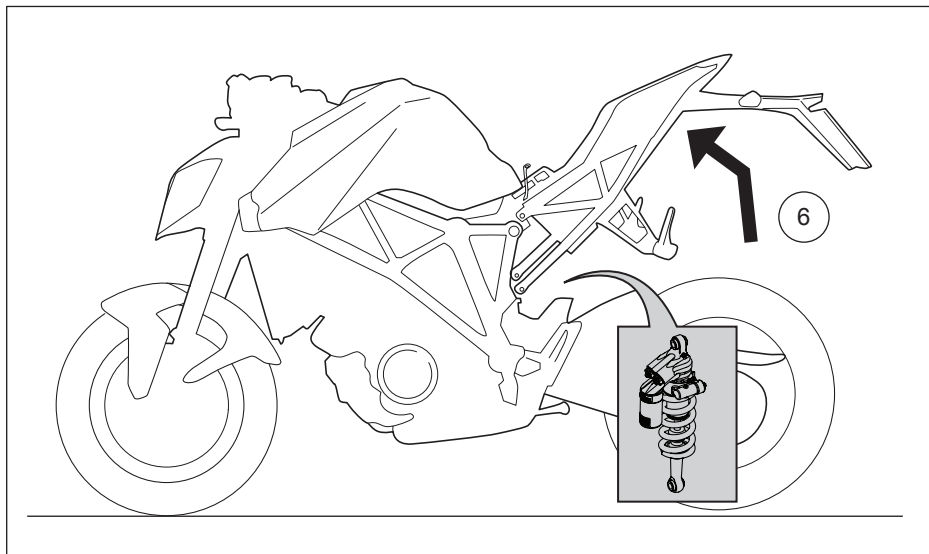

# ADJUSTMENTS

## **⚠ Warning!**

Before you ride/drive, always make sure that the setup is according to the recommended setup data. Read about adjustments and setting up in the Öhlins Owner's Manual before you make any adjustments. Contact an Öhlins dealer if you have any questions about setting up.

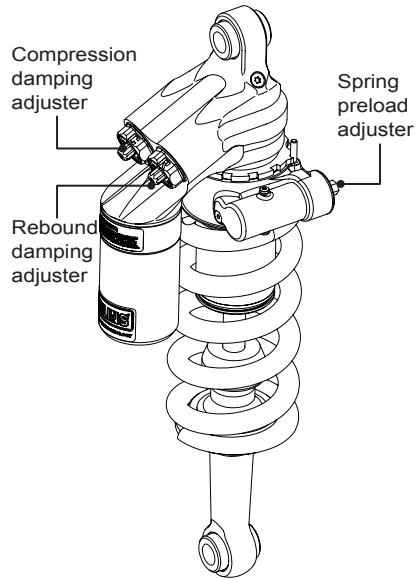

# SETUP DATA

Length	384	mm
Stroke	58	mm
Rebound	16	clicks
Compression	16	clicks
Spring part no.	01092-69	
Spring rate	170	N/mm
Spring free length	170	mm
Spring preload	5	mm

Recommended Free sag and Ride height		
R1-R3	50	mm
F1-F3	33	mm

Öhlins products are subject to continuous improvement and development, therefore, although these instructions include the most up-to-date information available at the time of printing, minor updates may occur.

To find the latest information contact an Öhlins distributor. Please contact Öhlins if you have any questions regarding the contents in this document.

Part no. MI\_KT302\_0  
Issued 2014-07-03

© Öhlins Racing AB. All rights reserved. Any reprinting or unauthorized use without the written permission of Öhlins Racing AB is prohibited.

Öhlins Racing AB  
Box 722  
S-194 27 Upplands Väsby, Sweden  
Phone +46 8 590 025 00  
fax +46 8 590 025 80



[www.ohlins.com](http://www.ohlins.com)