

Kit Contents

Description	Part No	Pcs
Top cap assembly		2
Preload tube	60060-08	2
Spring	68004-95	2
Sticker Öhlins white	01185-01	2
Sticker Öhlins blue	00192-01	2

Note!

Before installing this product, check the contents of the kit. If anything is missing, please contact an Öhlins dealer.

Warning!

Öhlins cannot be held responsible for any personal injury or damage that may occur after installing the Öhlins spring kit. We strongly recommend to let an Öhlins authorized service center to install this kit.

Warning!

After you have installed this product, take a test ride at low speed to be sure that your vehicle has maintained stability.

Note!

Please note that this image is a general representation of the product and may differ slightly from your product.

Note!

Please note that during storage and transportation, especially at high ambient temperature, some of the oil and grease used for assembling may leak and stain the packaging. This is in no way detrimental to the product, wipe off the excessive oil/grease with a cloth.

Fork Spring Kit for Yamaha MT-07

FSK 108

Mounting Instructions

MOUNTING INSTRUCTIONS

Original Front Fork assembly

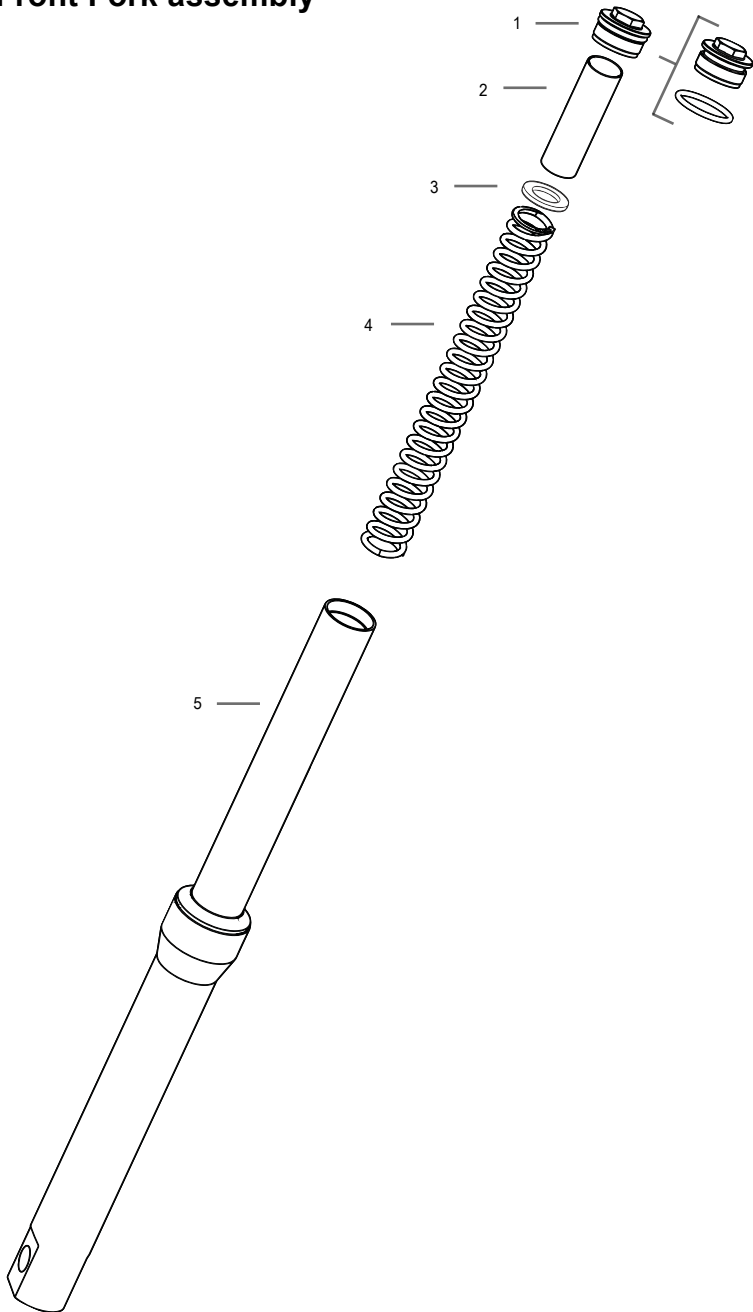

MOUNTING INSTRUCTIONS

Öhlins Front Fork kit assembly

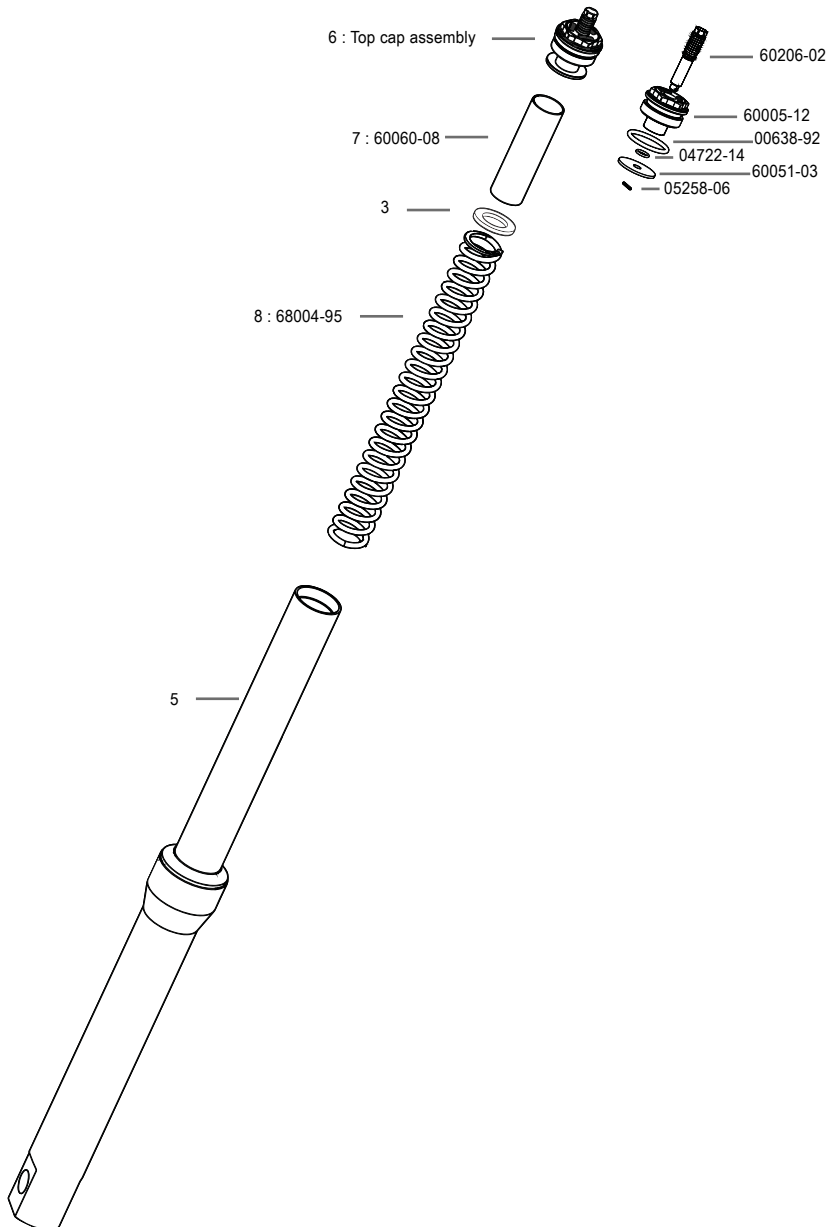

MOUNTING INSTRUCTIONS

Congratulations!

With this purchase you have made a clear statement. This high performance Front Fork spring kit from Öhlins is nothing but pure racing breed which means that you have taken one more step to eliminate luck on your motorcycle.

The balance between your Front Fork and rear suspension will sharpen up and the performance of your Front Fork will improve. Almost 40 years of racing experience is now a crucial part of your riding experience.

Note!

Öhlins FSK 108 gives the possibility to adjust the spring preload -5/+15mm from standard preload (8mm).

> Every complete turn equal 1mm adjustment

Note!

Öhlins FSK 108 spring 68004-95 rate is 9.5N/mm

Recommended oil

We recommended to use Öhlins high performance Front Fork fluid 01316-01.

Recommended oil Level

165mm.

Note!

The measurement of oil level is taken from the top of the inner tube (5) to the oil surface.

> The fork leg need to be in vertical position

> The fork need to be fully compressed

> The fork must be without the spring and the preload tube

Note!

During the installation of the fork damping kit, please be sure to don't damage the spring washer (3).

How to install

1. Put the motorcycle on the work stand so that the front wheel barely touch the ground. Make sure the motorcycle is in a stable position.
2. Release the fork tube from the top triple clamp.
3. Remove the original Top cap (1), Pre-load tube (2), Spring washer (3), and Spring (4)
4. Insert the Öhlins spring (8), Spring washer (3), Öhlins Pre-load tube (7)
5. Install the Öhlins Top cap assembly. Tighten the top cap at torque value ~10N/mm.

Öhlins products are subject to continuous improvement and development, therefore, although these instructions include the most up-to-date information available at the time of printing, minor updates may occur.

To find the latest information contact an Öhlins distributor. Please contact Öhlins if you have any questions regarding the contents in this document.

Part no. MI_FSK108_EN_0
Issued 2015-06-05

© Öhlins Racing AB. All rights reserved. Any reprinting or unauthorized use without the written permission of Öhlins Racing AB is prohibited.

Öhlins Racing AB
Box 722
SE-194 27 Upplands Väsby,
Sweden Phone +46 8 590 025 00
fax +46 8 590 025 80



www.ohlins.com