

Note!

Please note that there can be small differences between your product and the images in these instructions.

Note!

Please note that during storage and transport, especially at high ambient temperature, some of the oil and grease used for assembly may leak and stain the packaging. This will not cause damage to the product, wipe off the excessive oil or grease with a cloth.

Kit Contents		
Description	Part No	Pcs
Front fork type 43	FF 521	1
Screw MC6S M6x16	04757-05	4
Screw MC6S M8x16	04757-06	4
Screw MC6S M8x45	04757-09	4
Sticker set Öhlins		1

Note!

Before you install this product, check the kit contents. If anything is missing, please contact an Öhlins dealer.

Warning!

Before you install this product, read the Öhlins Owner's manual. This product is an important part of the vehicle and the vehicle stability.

Öhlins Front fork universal black

FF 521

Mounting Instructions

1 INFORMATION

Wheel shaft

The wheel axle must fit exactly into the 32 mm bracket holes of the fork bottom pieces. If the axle has smaller dimensions, correct axle sleeves must be used.

⚠ Caution!

It is of vital importance that the wheel axle diameter and length is correct: Axle sleeves must be aligned with the outer side of the bottom pieces. It is of vital importance that the axle can not pull the fork legs together.

👁 Note!

When fitting the wheel axle, apply some grease to the surfaces so the axle slides easily through the fork bottom pieces.

Fabrication

Use materials of high quality and adequate dimensions to fabricate sleeves, caliper brackets and fender brackets. The caliper bracket is mounted with M8 bolts and M6 bolts. The fender brackets are mounted with M5 bolts.

Torque information

M8 bolts: 19 Nm

M6 bolts: 7 Nm

M5 bolts: 4 Nm

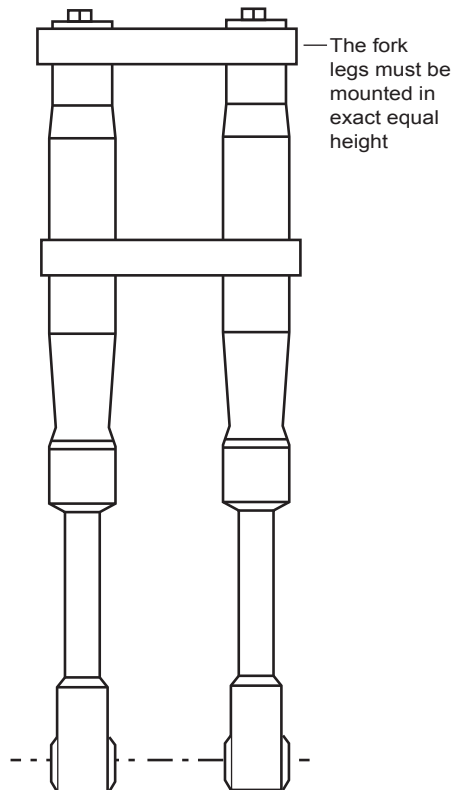
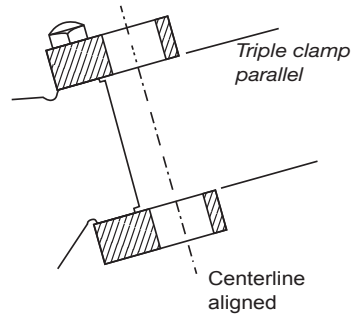

1 INFORMATION

Mounting recommendations

We recommend the mounting of the front fork to be performed by an authorized Öhlins dealer or by other skilled professional workshop.

Triple clamps

The fork triple clamps must be made with high accuracy and the fork leg mounts must be in an absolute straight line not to cause malfunctions.

Hole diameter upper triple clamp: 50 mm

Hole diameter lower triple clamp: 54 mm

Caution!

Not aligning the fork triple clamps will destroy the outer tube and bushings. Make sure that the fork legs are completely parallel and that they have the same height position in the triple clamps. Even very small differences may cause malfunction.

1 INFORMATION

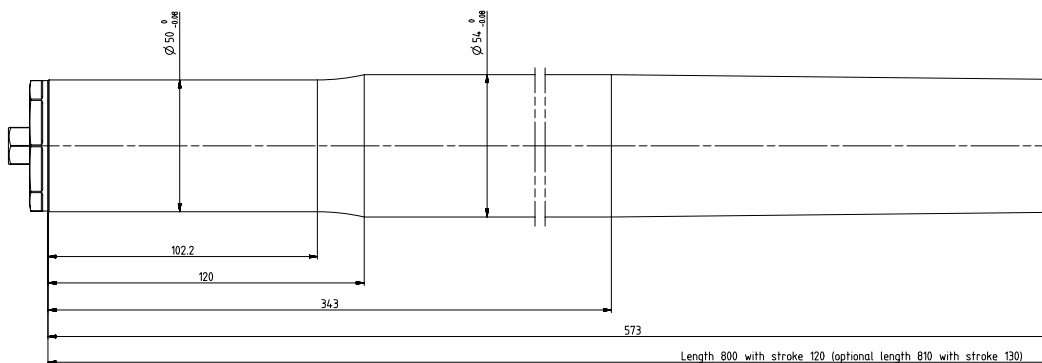

1 INFORMATION

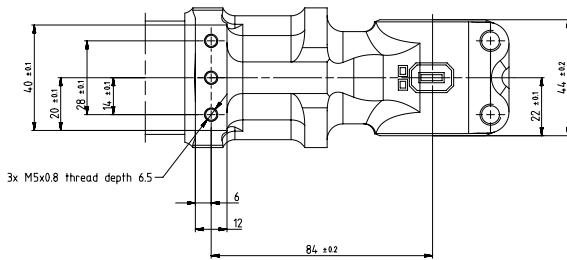
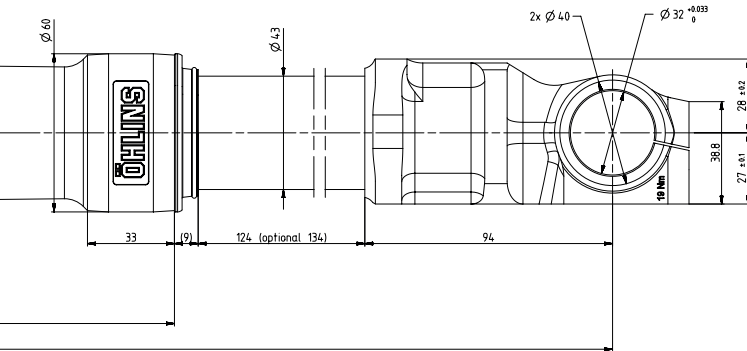
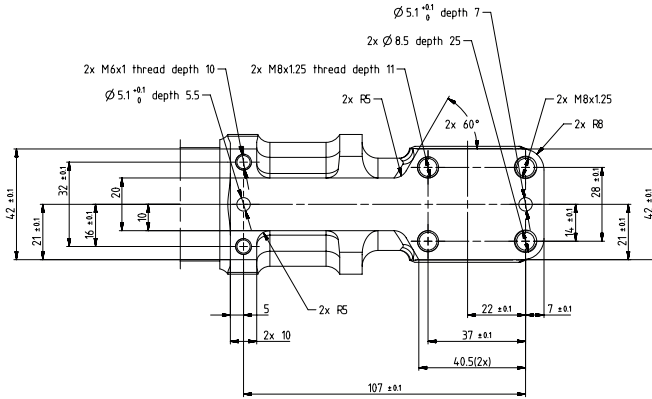

2 MOUNTING INSTRUCTIONS

⚠ Warning!

We strongly recommend to let an Öhlins dealer install this product.

⚠ Warning!

If you work with a lifted vehicle, make sure that it is safely supported to prevent it from tipping over.

👁 Note!

When you work with this product, see the vehicle service manual for vehicle specific procedures and important data.

👁 Note!

Before you install this product clean the vehicle.

1

Put the motorcycle on a work stand so that the front wheel barely touches the ground.

⚠ Warning!

Make sure the vehicle is securely supported so that it will not fall over.

2

Install the Öhlins front fork legs at the required front fork leg position. Please check standard front fork position. Turn the handle bars fully from side to side to make sure that nothing restricts the movement, and that the throttle cable and wire harness run in smooth bends.

3

Tighten triple clamps pinch bolts.

[Upper triple clamp 20 Nm]

[Lower triple clamp 10 Nm]

4

Install front fender, front wheel, caliper brackets and brake calipers. Do not tighten yet.

5

Put the vehicle on the ground, apply the front brake and compress the front fork distinctly 3-4 times. This will position the front fork legs Parallel.

6

Tighten front wheel axle, brake calipers and front fender.

[Front wheel axle pinch and M8 bolts torque 19 Nm]

[M6 bolts torque 7 Nm]

[M5 bolts torque 4 Nm]

7

Close compression and rebound adjusters.

8

Compress front fork as much as possible several times to release air trapped inside the damping systems. Ensure that there is damping on the full stroke.

9

Set compression and rebound adjusters according to chapter setup data.

👋 Caution!

Make sure that you tighten all bolts to the correct torque and that nothing fouls or restricts movement of the front fork when the suspension is fully compressed or extended.

⚠ Warning!

Certain modifications can be necessary to install the Öhlins front fork. It is vital that the mounting instructions are carefully followed.

3 ADJUSTMENTS

3.1 Measure sag

Main spring preload - Free sag - Ride height
 The main spring preload directly affects the front fork angle and the motorcycle height. Therefore, when you setup your motorcycle the main spring preload should be one of the first things to check.

1. Perform this procedure on a flat surface.
2. Place the motorcycle on a work stand so that both wheels are off the ground and the suspension is unloaded.
3. Use a piece of tape and mark a point straight above the rear wheel axle.
4. Measure the distance from the marked point to a fixed point, for example the wheel axle (R1). When measuring, make sure that the shock absorber is fully extended.
5. Measure the distance from the wheel axle to a fixed point, for example to the outer tube (F1). When measuring, make sure that the front fork is fully extended.
6. Place the motorcycle on the ground so that the front and the rear suspension are slightly compressed.
7. Repeat the measurement procedures (R2 and F2). Sit on the motorcycle in normal riding position and properly equipped in full riding gear. Repeat the measurement procedures (R3 and F3).

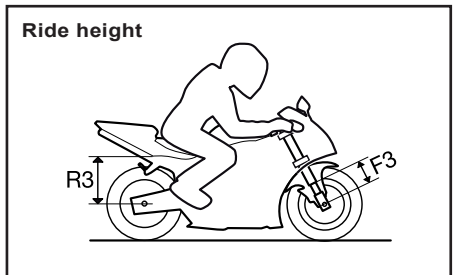
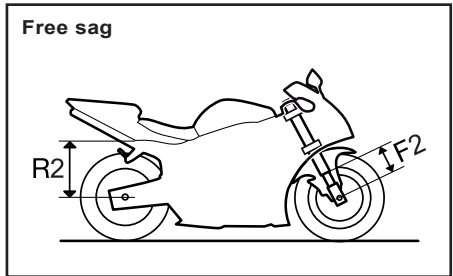
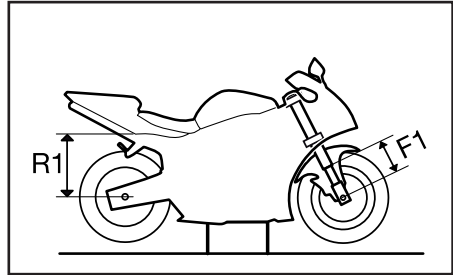

Note measurements			
R1		F1	
R2		F2	
R3		F3	

Recommended measurements

If no other recommendations are given in the Mounting instructions for your product, see the table below for recommended measures.

Sag pos.	Formula	Rec.
Free sag	$\frac{(F1-F2)}{\text{wheel travel}} \times 100$	~15-30 %
Ride height	$\frac{(F1-F3)}{\text{wheel travel}} \times 100$	~20-40 %

If the measurements differ significantly you may need to adjust the main spring preload or change the springs. Please see the Mounting Instructions for your front fork to find out more or contact an authorized Öhlins service center for advice.

⚠ Warning!

An incorrect main spring rate can give a faulty front geometry leading to under or over steering and seriously affect the ground clearance and vehicle handling.

3 ADJUSTMENTS

3.2 Adjusters

- **Compression damping adjuster**

Left hand side front fork leg.

- **Rebound damping adjuster**

Right hand side front fork leg.

Adjust Compression and Rebound;
Use a 3 mm hex key. Adjustment range from fully closed valve (clockwise) to fully open valve (counterclockwise) is about 25 "clicks". Set the recommended "clicks" from closed position according to chapter setup data.

- **Main spring preload adjuster**

Use a 14 mm wrench to turn the outer adjuster. Maximum adjustment range is 18 mm. Turn clockwise to increase and counterclockwise to decrease the preload. One turn corresponds to 1 mm change in preload.

3.3 Main spring

Due to variations in riding style, track conditions, body shape etc. the main spring is often a subject for additional fine-tuning.

Main springs are available in 0.5 N/mm intervals but the rate can be set to 0.25 N/mm increments by using two different rates.

Example:

Using 9.5 N/mm in the right hand side front fork leg and 10.0 N in the left hand side front fork leg gives a combined main spring rate of 9.75 N/mm.

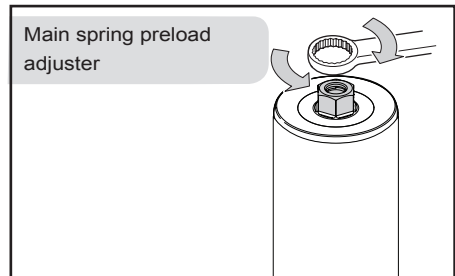
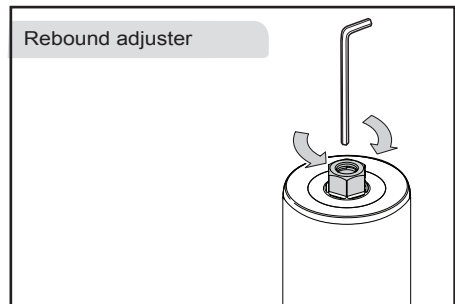
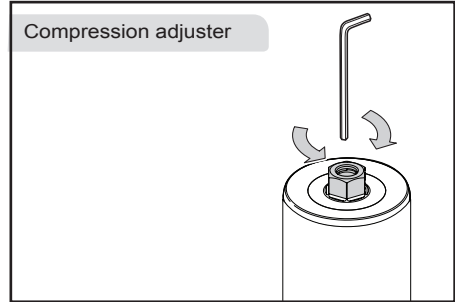

3 ADJUSTMENTS

3.4 Suspension fluid level

⚠ Caution!

Use only Öhlins high performance suspension fluid (01309-xx).

Suspension fluid level diagram

The diagram below shows reaction force curves at two different fluid levels. A change in the fluid level will mainly affect the air spring force and rate at the end of the front fork travel.

High fluid level

The air spring in the later half stage of travel is stronger which makes the front fork firmer.

Low fluid level

The air spring in the later half stage of travel is lessened which makes the front fork more linear.

Adjust suspension fluid level

👁 Note!

When measuring fluid level, remove main spring and associated parts according to chapter 3, make sure shaft assembly and outer tube are in their bottom positions. Measure fluid level with a ruler. See set-up data and suspension fluid level-force diagram in chapter setup data.

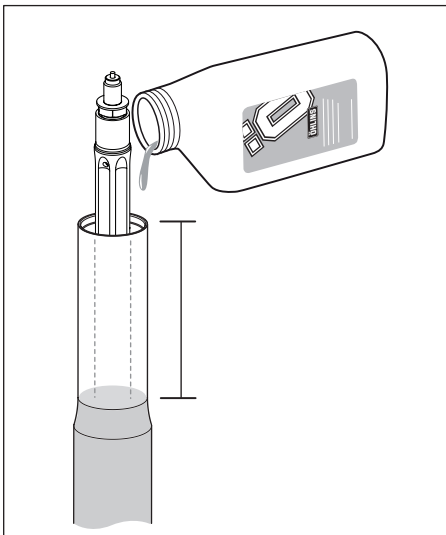

The diagram in chapter setup data shows several curves where each curve corresponds to a specific fluid level. For recommended fluid level, see chapter setup data.

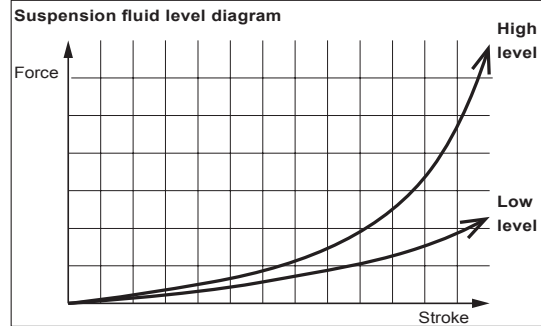

3.5 Front fork leg position

The front fork leg position changes the ride height at the front. To measure the front fork leg position; measure the distance between the outer tube and the upper triple clamp.

For recommended front fork leg position, see chapter setup data.

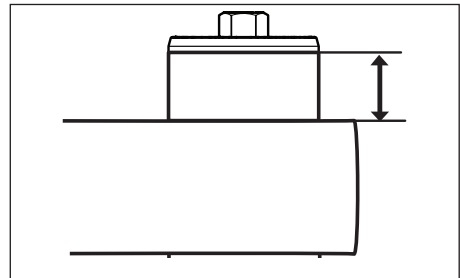

4 CHANGING THE MAIN SPRING/S AND CHECKING OR ADJUSTING THE FRONT FORK FLUID LEVEL

⚠ Warning!

This procedure requires high technical knowledge and/or experience of working with front forks. If you feel any insecurity regarding this procedure, contact an Öhlins dealer for advice. See the Vehicle Service Manual.

⚠ Warning!

Spring compression creates a potential danger because of the violent force that loaded springs are capable of. Beware of this when you work with the front fork.

1

Put the motorcycle on a workstand so that the front wheel barely touches the ground.

⚠ Warning!

Make sure the vehicle is securely supported so that it will not fall over.

2

Remove front fender, brake calipers, speed sensor (if present) and front wheel.

3

Release main spring preload by turning adjuster counter-clockwise until it stops.

[14 mm wrench].

4

Note front fork leg position.

5

Loosen upper triple clamp.

6

Loosen (do not remove) top cap ½ turn.

7

Loosen lower triple clamp.

8

Remove front fork legs from triple clamps.

9

Loosen top cap from outer tube.

10

Loosen top cap and remove it from shaft extension.

[14 mm and 19 mm wrench].

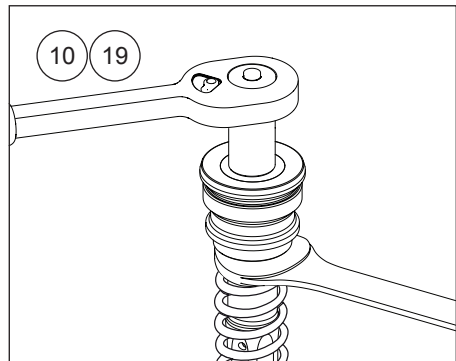
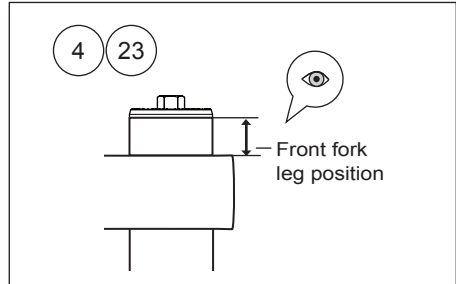

4 CHANGING THE MAIN SPRING/S AND CHECKING OR ADJUSTING THE FRONT FORK FLUID LEVEL

11

Remove spring support, main spring, preload tube.

12

Measure suspension fluid level and adjust if necessary, see chapter setup data.

13

Install special tool on shaft extension.
[01765-03 shaft extension tool].

14

Install main spring, with the marking facing upwards, and associated parts.

15

Pull up shaft assembly and insert tool in shaft extension.
[19 mm wrench].

16

Remove shaft extension tool.

17

Make sure compression and rebound bleed and main spring preload adjusters are fully opened, counterclockwise, before installing top cap.

18

Install top cap on shaft extension.
[14 mm socket, torque 30 Nm].

19

Remove 19 mm wrench tool.

20

Install top cap to outer tube at fully extended position.
[10 Nm].

21

Set compression, rebound and main spring adjusters [according to chapter setup data].

22

Install front fork legs in vehicle at position marked in point 4.

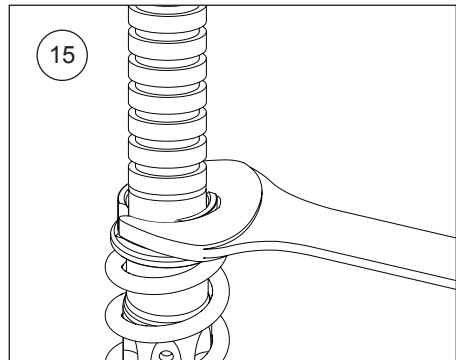
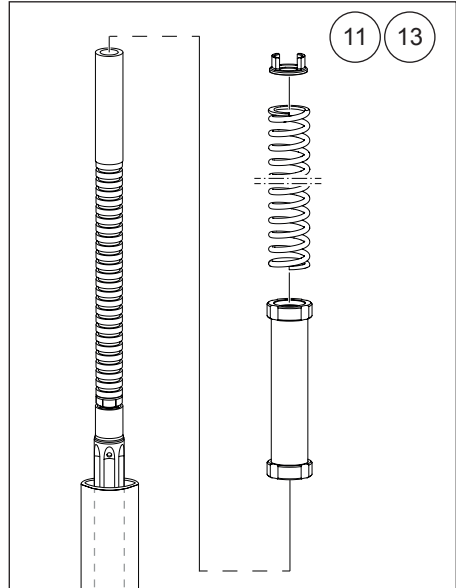

23

Remaining installation, see chapter mounting instructions.

5 TECHNICAL SPECIFICATIONS

Compression adjustment

Maximum open valve about 25 clicks.

Rebound adjustment

Maximum open valve about 25 clicks.

Main spring preload adjustment

0 - 18 turns (0 - 18 mm).

Main spring rate

See chapter setup data.

Suspension fluid level

See chapter setup data.

6 INSPECTION AND MAINTENANCE

Preventive maintenance and periodic inspection procedures help to keep the front fork in proper condition. For additional service, please contact an authorized Öhlins service center.

Caution!

Do not use strong detergents that can damage the front fork surfaces. Thinner and brake cleaner will dry out seals, increase the risk of friction, oil leakage and poor function.

Caution!

Use Öhlins High Performance Front Fork fluid 01309-xx.

Inspection points

1. Examine the fork leg for external oil leakage.
2. Examine the inner fork leg for scratches, dents or other defects that can damage the seal and/or bushing.
3. Examine the fender brackets and the brake calliper attachments.
4. Examine the front fork attachments to the vehicle.

Inspection intervals

Normal use: Once a year or every 5 000 km

Racing use: Every 10 hours

Service intervals

Normal use: Every third year or every 30 000 km

Racing use: Once a year or every 30 hours

Service at an authorized Öhlins service center.

Disposal

Hand over your discarded Öhlins products to an authorized Öhlins service center for proper disposal.

7 SETUP DATA

Recommended setup		
Length	800	mm
Stroke	120	mm
Compression adjustment	12	clicks*
Rebound adjustment	12	clicks*
Main spring preload adjustment	9	turns*
Suspension fluid level	150	mm*
Suspension fluid part number	01309-xx	

*When delivered from Öhlins.

Spring part no.		Rate [N/mm]
08790-80	Optional	8.0
04744-85	Included	8.5
08790-90	Optional	9.0
08790-95	Optional	9.5
08790-10	Optional	10.0

👁 Note!

Main springs 04744-xx are packed individually.
Main springs 08790-xx are packed in pairs.

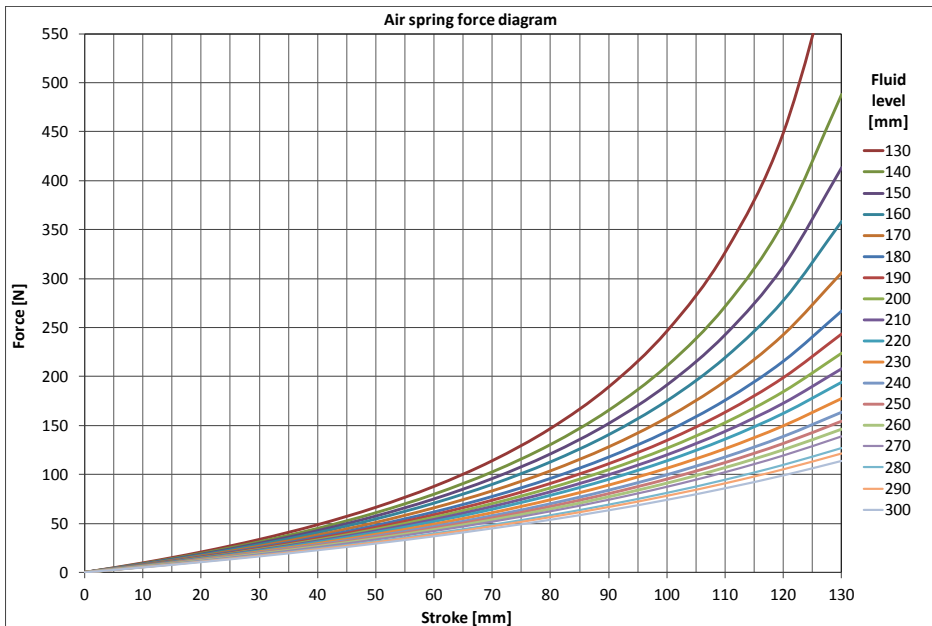

Öhlins products are subject to continuous improvement and development, therefore, although these instructions include the most up-to-date information available at the time of printing, minor updates may occur.

To find the latest information contact an Öhlins distributor. Please contact Öhlins if you have any questions regarding the contents in this document.

Part no. MI_FF521_0
Issued 2019-06-13

© Öhlins Racing AB. All rights reserved. Any reprinting or unauthorized use without the written permission of Öhlins Racing AB is prohibited.

Öhlins Racing AB
Box 722
S-194 27 Upplands Väsby, Sweden
Phone +46 8 590 025 00
fax +46 8 590 025 80



www.ohlins.com